



ESCE

Modes d'Exportation: Classification et Sélection

Claude Obadia



cgi

La Confédération
Française du Commerce
Interentreprises



think tank
**La Fabrique
de l'Exportation**



ESCE

Mode d'Exportation

- La structure organisationnelle mise en place par une entreprise pour exporter



think tank
**La Fabrique
de l'Exportation**

© Claude Obadia, 2014



Intégration vs. Délégation

ESCE

<ul style="list-style-type: none"> • Intégration ou Internalisation 	<ul style="list-style-type: none"> • Délégation ou Externalisation
<p>Réalisation d'une tâche en interne</p>	<p>Délégation d'une tâche à une tierce partie.</p>



© Claude Obadia, 2014



Modes d'Exportation

ESCE

INTEGRES	DELEGUES
<ul style="list-style-type: none"> • Vente en direct (Direct Sales) • Filiale Commerciale (Sales Subsidiary) • Bureau de Représentation (Sales Office) 	<ul style="list-style-type: none"> • Négociant Export (Trading Company) • Agent Export (Export Management Company) • Distributeur/Importateur (Foreign Distributor) • Agent Import (Foreign Agent)
<ul style="list-style-type: none"> • Franchising (1) 	<ul style="list-style-type: none"> • Licensing • Franchising (2) • Franchising (3)



© Claude Obadia, 2014

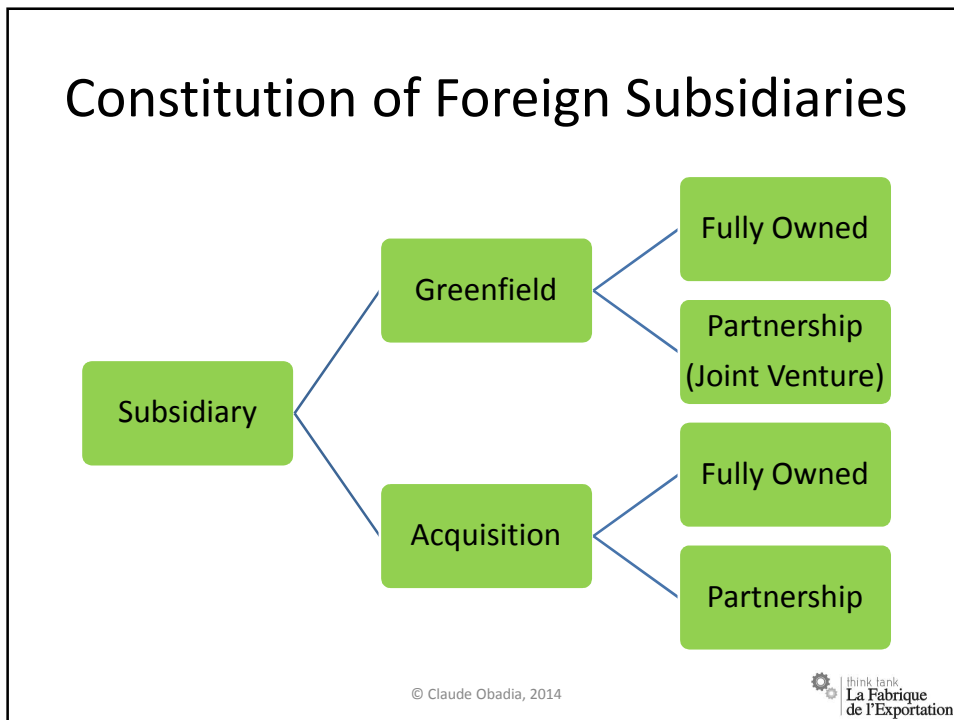
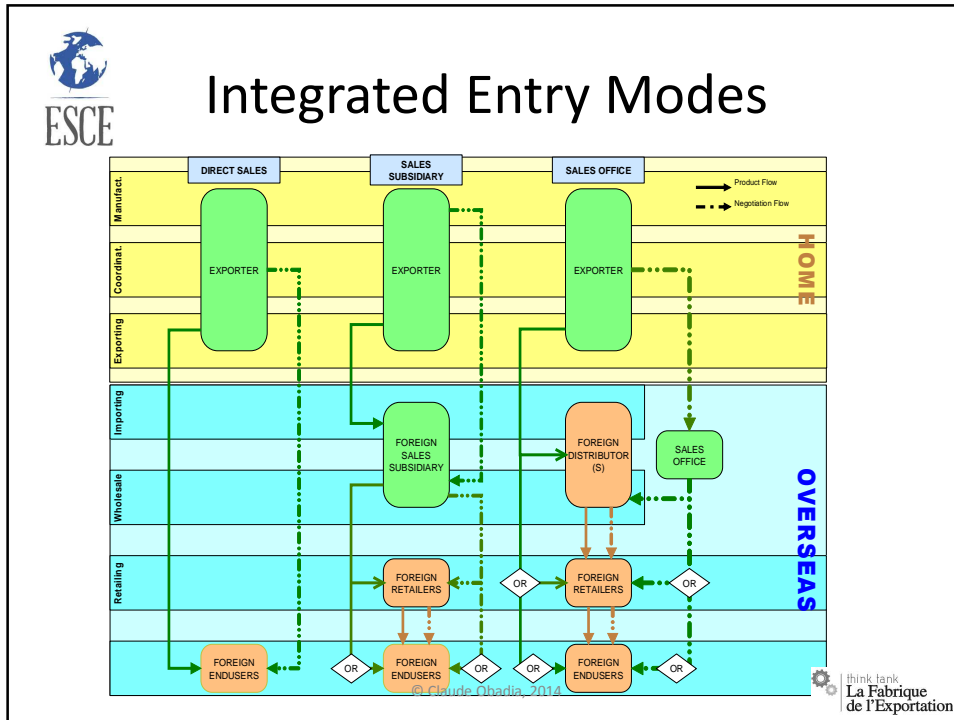

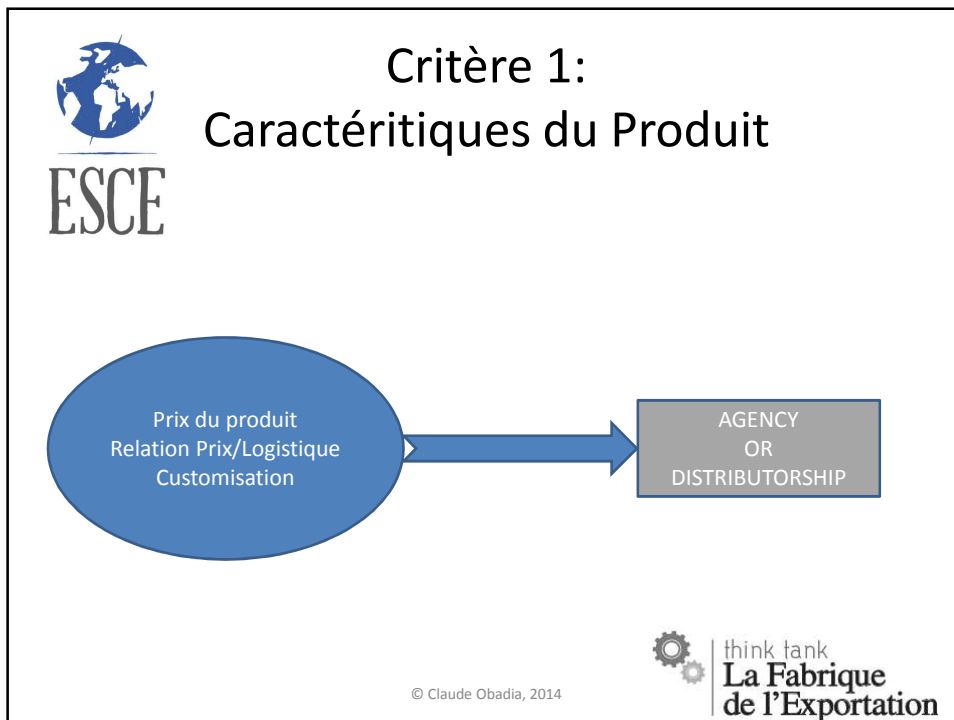
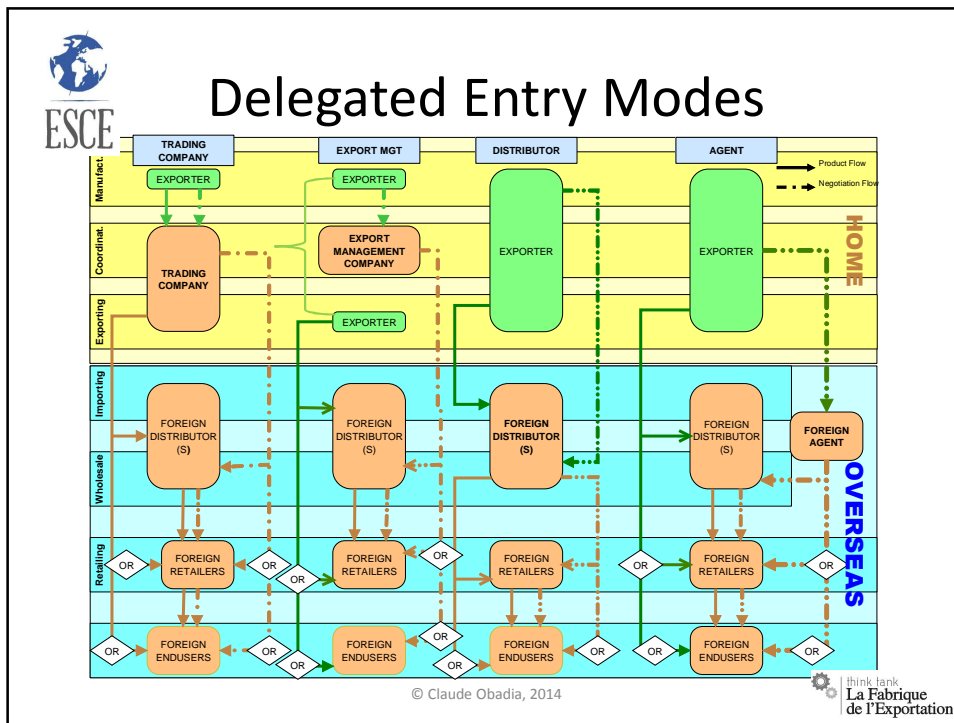

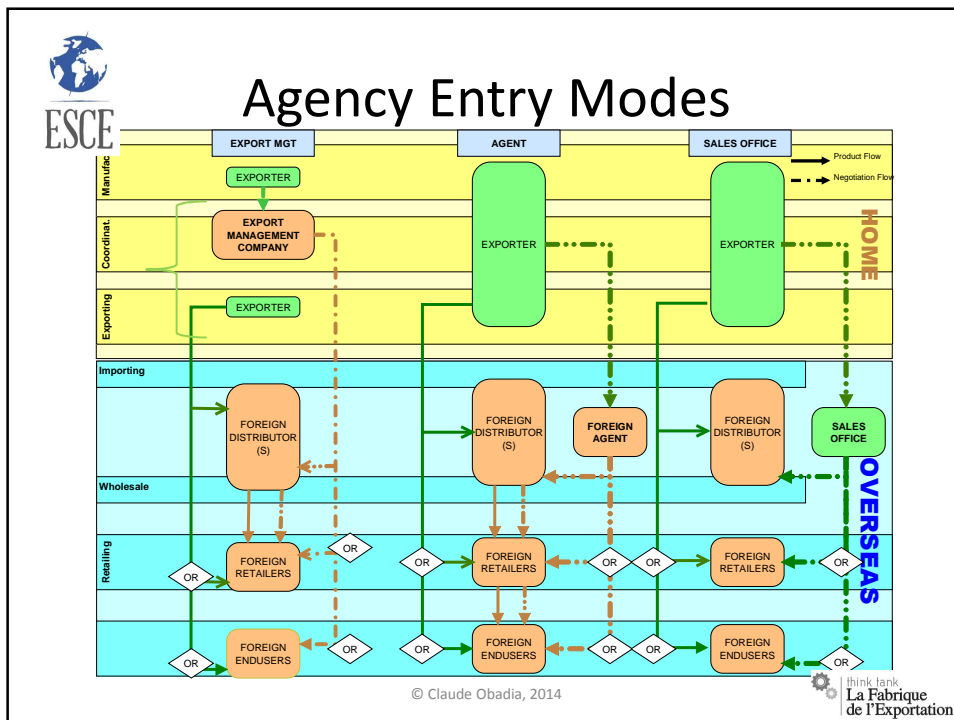
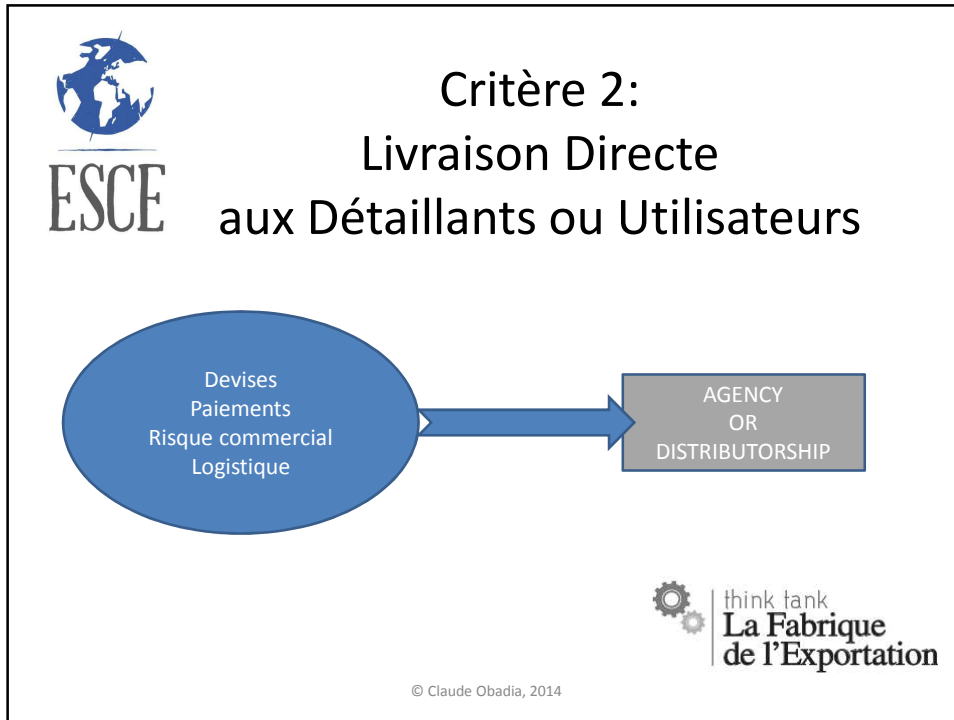

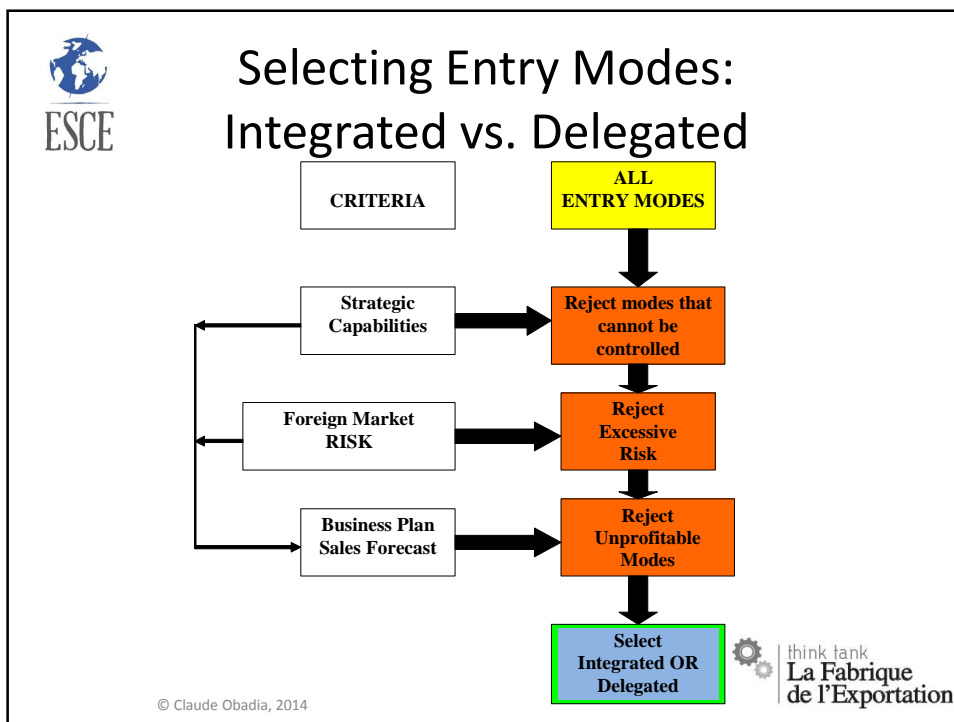
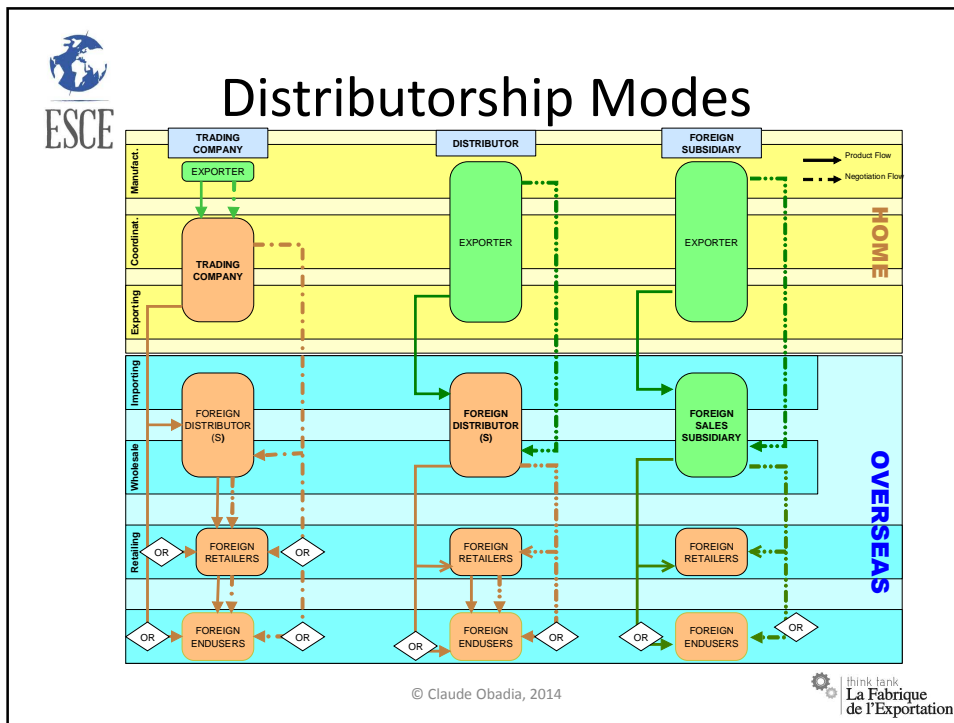



Capacité Stratégique de l'Exportateur

<p>Ressources</p> <ul style="list-style-type: none"> • Personnel qualifié (disponibilité) • Cash Flow • Réseau dans le marché étranger 	<p>Compétences</p> <ul style="list-style-type: none"> • Gestion d'opérations externes et internationales • Marketing International: <ul style="list-style-type: none"> Sélection de marchés Prospecting Négociation commerciale /contrats Vente/Après-vente Marketing aux détaillants/utilisateurs locaux • International Sales Administration: <ul style="list-style-type: none"> Finance Logistique Réglementation / Permis • Expérience dans le marché étranger
--	---

© Claude Obadia, 2014



Sources du Risque à L'Export



Sources Du Risque

- Risque Commercial
- Délinquance Economique
- Risque de Change
- Risque Politique
- Risque Culturel

© Claude Obadia, 2014





Le Risque à l'Export

Marché Etranger

$$R = \text{€} * P$$

Mode d'Exportation

© Claude Obadia, 2014



La Composante Financière du Risque

€ =

- Investissement initial
- Cash-Flows
- Encours
- Propriété intellectuelle

© Claude Obadia, 2014



En partenariat avec:



© Claude Obadia, 2014